

# Product Manual

## QMOD™ HD Modulator-IPTV Encoders



August 2018



4355 Excel Pkwy, Suite 600, Addison, TX, 75001  
Phone: 972-931-2728 • Toll-Free: 888-972-2728 • Fax: 972-931-2765  
E-Mail: [Support@crwww.com](mailto:Support@crwww.com) • Website: [contemporaryresearch.com](http://contemporaryresearch.com)

# Table of Contents

---

<b>Table of Contents</b> .....	<b>2</b>
<b>Overview</b> .....	<b>3</b>
<b>Video and Audio Assignment</b> .....	<b>4</b>
<b>Installation Overview</b> .....	<b>5</b>
First Things.....	5
Inputs.....	5
Scaling.....	5
Advanced Setup.....	5
IPTV.....	5
EAS Emergency Alert Service .....	5
Web Pages .....	5
Reset Options (Just a short press on designated buttons) .....	5
<b>Front Panel Menus and Web Pages</b> .....	<b>6</b>
Quick Setup Menus.....	6
Program A and Program B .....	7
Common .....	8
Advanced .....	9
Web Pages .....	9
<b>Updating Firmware with CR Toolbox</b> .....	<b>10</b>
<b>Converged RF and IPTV Distribution</b> .....	<b>11</b>
<b>Using VLC Media Player to Test Streaming</b> .....	<b>12</b>
QMOD Setup.....	12
VLC Setup.....	12
<b>RKU Universal Rack Mount Kit</b> .....	<b>13</b>
<b>Specifications</b> .....	<b>14</b>
<b>QAM Channel Chart, Center Frequency</b> .....	<b>15</b>
<b>Safety Instructions and Warranty</b> .....	<b>16</b>

The software included in this product contains copyrighted software that is licensed under the GPL. You may obtain the complete Corresponding Source code from us for a period of three years after our last shipment of this product. Request this and current GNU version information by contacting Contemporary Research, [contemporaryresearch.com/contact/contact-us/](http://contemporaryresearch.com/contact/contact-us/).

## Overview

---



Each modulator has a different mix of video and audio inputs, so the menus for each are different – but all the rest of the menus and Web choices are the same. There are also differences in which Video input is available, as noted below. You can always use the video inputs for receiving closed captioning data. All models feature:

- Dual-program encoding for MPEG2 or H.264, UDP or RTP
- End-to-end RF MPEG2 latency reduced to 500 ms
- Hardware scalers for each program, accepts up to 1080p 60, 1080psf24/23.97, VGA and PAL standards
- Outputs as a dual-program SPTS stream for RF, individual MPTS streams for IPTV
- RF QAM channels are agile from 2-135
- Universal firmware app updates all models over Ethernet and USB
- Set up and monitor from front panel menus or onboard Web pages via Ethernet and USB
- Can distribute channels in QAM (cable) or 8VSB (off-air) format

### QMOD-HDMI RGB

- One HDMI input (all HDMI sources must be unencrypted for HDMI models)
- One RGBHV/Component input (a DB15 to Component cable is included)
- Two Composite/CC video inputs for encoding, or captioning
- Two analog Stereo and two SPDIF coax audio inputs

### QMOD-HDMI 2

- Two HDMI inputs
- Two Composite/CC video inputs for encoding, or captioning,
- Two analog mini Stereo and two RCA SPDIF coax audio inputs

### QMOD-SDI HDMI

- One SDI (up to 3G, 8 SDI audio pairs) and one Component input
- One HDMI input
- One Composite/CC video input for encoding or captioning
- One RCA analog Stereo and one each SPDIF coax and optical audio inputs

### QMOD-SDI 2

- Two SDI inputs, up to 3G, 8 SDI audio pairs
- Two Composite/CC video inputs for encoding, or captioning,
- Two analog mini Stereo and two RCA SPDIF coax audio inputs

### QMOD-YPB2

- Two Component inputs
- Two Composite/CC video inputs for encoding, or captioning,
- Two analog mini Stereo and two RCA SPDIF coax audio input

# Video and Audio Assignment

Each QMOD has a set of rules regarding how video and audio is selected for Program A and B, with limits primarily for SDI inputs and audio. The X/Y table for each shows valid input combinations for Programs A and B. For example, reading across for the QMOD SDI 2, you can select SDI 1, SDI 2, or Video 2. Reading down for Program B, you can select SDI 1, SDI 2, or Video 1. Audio and caption notes are included as well.

**QMOD-SDI 2**

Program A	Program B			
	SDI 1	SDI 2	Video 1	Video 2
SDI 1	✓	✓	X	✓
SDI 2	✓	✓	✓	X
Video 1	X	✓	✓	✓
Video 2	✓	X	✓	✓

**Audio Restrictions** – You cannot select:

- SDI 1 pairs if Video 1 is selected as a video input.
- SDI 2 pairs if Video 2 is selected as a video input.
- More than two SDI 1 or SDI 2 pairs (of 8 pairs)
- Both SPDIF inputs and more than one SDI pair from the same SDI input
- The same audio pair for Programs A and B if one SDI input is patched to both encoders

**Captions** - You cannot select:

- SDI 1 closed captions if Video 1 is selected
- SDI 2 closed captions if Video 2 is selected

**QMOD-SDI HDMI**

Program A	Program B			
	SDI	HDMI	Video 1	Video 2
SDI	✓	✓	X	✓
HDMI	✓	✓	✓	X
Video 1	X	✓	✓	✓
Video 2	✓	X	✓	✓

**Audio Restrictions** - You cannot select:

- SDI pairs if Video 1 is selected
- More than 2 SDI pairs (of 8 pairs)
- Both SPDIF inputs and more than 1 SDI pair

**Captions** - You cannot select:

- SDI closed captions if Video 1 is selected

**QMOD-HDMI RGB, QMOD-HDMI 1.5**

Program A	Program B				
	HDMI	YPbPr	RGBHV	Video 1	Video 2
HDMI	✓	✓	✓	✓	X
YPbPr	✓	✓	X	X	✓
RGBHV	✓	X	✓	X	✓
Video 1	✓	X	X	✓	✓
Video 2	X	✓	✓	✓	✓

No audio or caption restrictions

**QMOD-HDMI 2**

Program A	Program B			
	HDMI 1	HDMI 2	Video 1	Video 2
HDMI 1	✓	✓	X	✓
HDMI 2	✓	✓	✓	X
Video 1	X	✓	✓	✓
Video 2	✓	X	✓	✓

No audio or caption restrictions

**QMOD YPB2**

Program A	Program B			
	YPbPr 1	YPbPr 2	Video 1	Video 2
YPbPr 1	✓	✓	X	✓
YPbPr 2	✓	✓	✓	
Video 1	X	✓	✓	✓
Video 2	✓	X	✓	✓

No audio or caption restrictions

# Installation Overview

---

## First Things

Always start by defining channel, video and audio inputs by selecting the QUICK menu. Press SETUP, move left or right and press SELECT. Use Up - Down and Right – Left, then SELECT to save your choices. At this point, test operation with a local TV.

The default RF level is 29 dBmv. If the application requires a lower level, use RF attenuators to reduce the level. There is a menu where the levels can be reduced down to 9 dBmv, but lowering the RF level can impact channel quality, especially for channels 2-6.

That's a key point – with a local TV you can see your results immediately, verifying correct operation before distributing the channel through the RF system. It helps to know it's working in the rack – then check performance at each TV.

**Re-scan the channels when the install process is complete** – the TV won't know the channel information until it scans. That's the value of a local TV – once everything is defined, remote TVs are only scanned once.

## Inputs

Just a few things to know:

- **HDMI** – Input can't pass encrypted HDCP content, accepts up to 1080p - and 59.94/60/30 Hz, VGA standard, and PAL video is scaled as well. For more information, view our Support Blog on [Using HDMI Sources](#).
- **SDI** – Accepts up to 1080p 3G video, as well as 30/60 Hz and PAL refresh rates. Captioning can be embedded or from the CC port, audio is embedded or from a separate audio input. Now users can select SDI audio pairs 1-8.
- **RGBHV** – Accepts most HD and VGA resolutions and scaling generally creates a correct image for TVs
- **Component** – use the free HD15 to Component cable for the QMOD-HDMI 1.5, which can accept 1080p video
- **Video** – accepts NTSC or PAL video, check the previous page for rules
- **None** – choose None for the Program B, making the modulator a one-channel unit
- **Audio** – Encoder will pass through AC-3, stereo PCM and analog can be encoded as AAC, AC-3 or MP12

## Scaling

In general, PC presentations via HDMI 1080p will be very close edge-to-edge, as the data from HDMI gives us the information needed to exactly scale the image. Some TVs vary in how they present the scaled image, the best for LG will be the Just Scan mode, Normal for Visio, or similar for other brands. This will be similar for 1080p RGBHV PC video - for resolutions less than 1080p horizontal and vertical Zoom, Left, Right, Up, and Down positioning may be needed to correctly display the image. If the video source is 1080p, and the program is set to IP only and Auto Res On, the stream will be encoded as 1080p.

## Advanced Setup

Front-panel menus can be used for all settings, but the Web pages can speed up the process for advanced settings.

## IPTV

It's hard to get into all the issues here, but yes, the MPEG stream can be output as a QAM RF channel, IPTV channel, or as both. For 2 programs, RF will carry a single MPTS stream, and IP will send two independent SPTS streams. Unicast, where the stream is pointed at one specific player, works on most networks. Multicast will only work if all of the site's routers and switches support Multicast IGMP operation. Streams can be sent in UDP or RTP formats

## EAS Emergency Alert Service

Any video and audio input can be set as the EAS source. A latching contact closure (NO –GND to SW) or 5-24 VDC voltage (GND to V+) will trigger the event. The EAS AV will be sent through both programs when active, and reverts to the original inputs when released.

## Web Pages

You can access the Web pages via a network, or from the front-panel USB port; the internal IP address is 192.168.227.227. See Support Blog <http://contemporaryresearch.com/dougs-q-tips-viewing-web-pages-usb-port/> on setting up the IP connection.

## Reset Options (Just a short press on designated buttons)

- Pressing the **Left** and **Right** arrows does a soft encoder reboot (some components like HDMI aren't reset)
- Resetting **DC power** will reset all system components without changing settings
- Pressing **Left** and **Right** arrows during power-up resets to your custom settings (see Advanced Menu page)
- Pressing **Up** and **Down** during power-up **clears everything**, resets to factory settings – use with caution

## Front Panel Menus and Web Pages

The following menus are the same for all QMOD HD Modulators/IPTV Encoders. We will base the examples on the **QMOD-HDMI 1.5**, the unique video and audio input selections are noted on Page 4.

- **Front Panel.** Press the SETUP button use the Up/Down buttons to move through menus, Left/Right to change settings, then press SELECT to store the changes at each step.
  - Select a menu group (**Quick, A, B, Common, Advanced**), then SELECT to view that group's menus
  - Press SETUP to move back to other menu groups
  - Pressing the left and right buttons together will reboot the unit
- **Ethernet.** Access the onboard Web pages. Helpful for remote access when system is fully integrated with site.
- **USB-Web.** Access Web pages from front-panel USB port, simplest solution for full setup, requires no IP setup or connection, connect from the front of the equipment rack.

### Front Panel Menus

There are five groups of menus you can choose from:

- **Quick Setup** supplies just the few steps needed to output the source as a channel.
- **Program A** goes deeper in to all the options for the first source
- **Program B** does the same for the second program
- **Common** menus set the core values for the entire QMOD, such as IP address, LCD and RF settings
- **Advanced** menus set special options for Program A and B, Common settings

### Quick Setup Menus

This series is designed for a quick setup for testing and integration. (Example is QMOD-HDMI RGB)

Channel	Sets the physical channel, 2-135
RF Level dB	Sets the RF level for the channel <b>29   25   21   17   13   9</b>
Video A Inpt	Selects the video input for Program A <b>HDMI 1   YPbPr 1   RGBHV 1   Video 1   Video 2</b>
Audio A Inpt	Selects the audio input for Program A <b>None   HDMI 1   SPDIF 1   SPDIF 2   Analog 1   Analog 2</b>
Video B Inpt	Selects the video input for Program B (if enabled) <b>None   HDMI 1   YPbPr 1   RGBHV 1   Video 1   Video 2</b>
Audio B Inpt	Selects the audio input for Program B (if enabled) <b>None   HDMI 1   SPDIF 1   SPDIF 2   Analog 1   Analog 2</b>

At this point, you should be able to view the QMOD channels on a test TV. Note that setting Video B input to **None** will automatically put the encoder in to single-channel mode, and revert to 2-channel mode when inputs are selected for Program A and B.

A QMOD channel, or any QAM channel, can include two video streams, called Programs. It's really one stream that contains both videos. The TV figures out which to play using the channel ID, typically something like channel IDs 2.1 and 2.2, 3.1 and 3.2 and so on. For marketing purposes, we use the popular term "2-Channel" the general public understands, for integrators we use the more correct term "2 Programs".

## Program A and Program B

There are two separate menus for Program A and B (Input examples for QMOD-HDMI RGB)

Encoder Settings	Sets video and audio properties for the program
Video Input	Select the video input (Program B adds the option to select <b>NONE</b> ) <b>HDMI 1   YPbPr 1   RGBHV 1   Video 1   Video 2</b>
Input Res	Displays resolution of current source
Output Res	Set the Program output resolution, auto resolution will override this setting <b>1080i   720p   480p   480i   576i</b>
Auto Out Res	When set to <b>On</b> , the QMOD will automatically output the program as the same resolution as the source. Default is On. If video is 1080p, IP only and Auto Out Res on, program will be 1080p. <b>On   Off</b>
Vid Bitrate	Bitrate is adjustable in half steps from 8-20 Mbps for <b>MPEG2</b> , 5-10 for <b>H.264</b> HD, 2-4 for SD. Default rate will be 18 or 9 Mbps, set to 18 or below for dual-channel operation.
Video Format	Select <b>MPEG2</b> or <b>H.264</b>
Aspect Ratio	Menu visible when there is a 480i source. Sets the video to display the 480i video as 4:3 or 16:9. <b>4:3   16:9</b>
Bitrate Mode	Only visible when QMOD outputs on Ethernet only. Selects <b>Constant</b> or <b>Variable</b> rate
Aud 1 Input	Sets audio for the currently selected source. If you plan on switching sources in your application, select each video input, then select the associated audio. The audio will then automatically follow the selected video input. <b>None   HDMI 1   SPDIF 1   SPDIF 2   Analog 1   Analog 2</b> (SDI can select pairs 1-8)
AudInFormat	Displays input audio format. <b>Analog   PCM   AC3   AAC</b>
Aud 1 Format	Selects audio format for stereo PCM or analog audio. <b>AC3   AAC   MP12</b> (AAC for IP – not all TVs can play AAC via RF, MP12 is MPEG1, Layer2)
Aud 1 Lang	Displays metatext for audio channel language. <b>English   Spanish   Portuguese   French   German</b>
Aud 2 Input	Sets the source for the second SAP audio track for the selected video input. Audio will be in MPEG 1 Layer 2 format <b>None   HDMI 1   SPDIF 1   SPDIF 2   Analog 1   Analog 2</b> (SDI can now select pairs 1-8)
Aud 2 Lang	Displays metatext for SAP audio channel language. <b>English   Spanish   Portuguese   French   German</b>
Major Chan	Major virtual channel ID for program. Default is 000, will automatically insert the physical channel number as the Major ID.
Minor Chan	Minor virtual channel ID. Default is 1, if set to 000, channel ID will only use the Major channel ID
Chan Name	Enters channel short name, up to 7 characters. QMOD A or QMOD B is default text. Press right or left arrow to start editing, use Up and Down arrows to select character.
No Vid Color	Sets background color displayed when no video is present <b>Orange   Purple (default)   Green</b>
Sync TrigLev	May help how fine details are displayed for component input <b>1-4</b> . Only on Web page.
Clock Phase	RGB/Component input, can improve sharpness for some videos or signage <b>1-6</b>
CC Source	Selects source for captioning, Line 21 from NTSC, 708/608 from SDI <b>None   Video 1   Video 2   SDI 1   SDI 2</b>
Horiz Freq	Shows horizontal frequency of source
Vert Freq	Shows vertical frequency of source
Lines	Shows number of lines in source video
Output Mode	Select outputs for streaming <b>RF   IP   RF+IP</b>

More on next page

<b>IP Settings</b>	<b>Defines streaming properties</b>
UDP Mode	Selects UDP mode, sub menus change depending on mode <b>Unicast   Multicast</b>
Eth Protocol	Selects <b>UDP</b> or <b>RTP</b> Ethernet protocol
Dest Uni Addr	Enter destination IP address for unicast
DstMultiAddr	Enter IP address for multicast
Dest IP Port	Enter UDP port for unicast or multicast
<b>Scaler</b>	<b>Zoom and Positioning</b>
Horiz Adjust	At the Horizontal menu, press the SELECT button to start the process – you will see a white bar in the middle of the QMOD display. - Up zooms the video horizontally, while Down scales the video down - Left moves the video left, Right moves the image right - The solution is automatically saved for that resolution. Repeat for other resolutions, if needed
Vert Adjust	Same as above, Up/Down positions video, L/R zoom and shrink

## Common

This series of menus sets global values for QMOD operation.

Channel	Sets the physical channel, <b>2-135</b>
Modulation	Selects QAM 64 or QAM 256 (default). Fixed at 256 when 2-channel mode is enabled. Continuous Wave is often used to test the channel with a meter. Air 8VSB modulates channels as off-air channels. <b>QAM-256   QAM-64   QAM-CW   Air 8VSB</b>
Cable format	Standard cable frequencies (default) <b>HRC</b> – same as Standard, channels 5 and 6 slightly different <b>IRC</b> – All channel frequencies are different than the standard cable setting
RF Level dB	Sets the RF level of the channel in dBmv. <b>29   25   21   17   13   9</b>
LCD Contrast	Contrast <b>1-15</b>
LCD Bright	Display brightness <b>1-16</b> (if you set too low, you can change via Web page)
Clear PWD	Press Select to clear password
IP Mode	<b>Static</b> or <b>DHCP</b> an asterisk (*) after DHCP means there is no IP connection or other IP issue
IP Address	<b>192.168.001.231</b> Left/Right steps through each group, click Up or Down arrow to step one at a time, hold down to move faster. Address also appears on LCD when QMOD restarts.
Gateway	<b>192.168.001.010</b> Quad address – Left/Right steps through each group, click Up or Down arrow to step one at a time, hold down to move faster.
Subnet Mask	<b>255.255.255.000</b> Subnet has a limited range of combinations, so this function is simplified Left/Right steps through each group, click Up or Down arrow for options
Mac/SN	Displays Mac address - the last 3 pairs identify the serial number
Unit Name	Create unique name for the QMOD
QMOD Version	Starts with current version, use left and right arrows for versions of all software modules



## Advanced

This series of menus sets global values for QMOD operation.

A-Pgm Number	Sets a specific Program number <b>1-65535</b> , default is 1 for A, 2 for B.
A-Source ID	Sets Source ID <b>1-65535</b> , Often used to match program number for emulating Guide channel in cable systems.
A-Bitrate Mode	Only visible when QMOD outputs on Ethernet only. Selects <b>Constant</b> or <b>Variable</b> rate
A-QMODIPPort	Sets Source IP port for streaming (2728 default)
A-Mcast TTL	Time To Live function assures that multicast streams don't loop forever when they're not being used. 0-255 - Typical settings: 0- restricted to the same host, will not be forwarded by any interface 1-restricted to the same subnet, won't be forwarded by router 32-(default) restricted to the same site 64- restricted to the same region 128- restricted to the same continent
A-AVDropped	Counts the number of frames dropped for testing, press right arrow to clear
A-MPEG2DcdDly	Sets encoding MPEG2 delay from 200 to 500 ms. Note that the internal buffer adds 150 ms, and typical decoding delay for TVs is about 150 ms, so end-to-end latency is about 500 ms.
A-MPEG4DcdDly	Sets encoding MPEG4 delay from 300-500 ms. See above.
B-Pgm Number	Sets a specific Program number <b>1-65535</b> , default is 1 for A, 2 for B.
B-Source ID	Sets Source ID <b>1-65535</b> .
B-Bitrate Mode	Only visible when QMOD outputs on Ethernet only. Selects <b>Constant</b> or <b>Variable</b> rate
B-QMODIPPort	Sets Source IP port for streaming (2728 default)
B-Mcast TTL	0-255 This Time To Live function assures that multicast streams don't loop forever.
B-AVDropped	Counts the number of frames dropped for testing, press right arrow to clear
B-MPEG2DcdDly	Sets encoding MPEG2 delay from 200 to 500 Ms. Average TV decoding delay is 150 Ms.
B-MPEG4DcdDly	Sets encoding MPEG4 delay from 300-500 Ms
Fan Speed	Fan speed in percent, operation is automatic
Temperature	Processor temperature, tends to hover around 139 degrees
EAS Video	Selects video input to use when an Emergency Alert has been triggered, may be any input
EAS Audio	Selects audio input to use when an Emergency Alert has been triggered, may be any input
IP TS Mode	Sets <b>SPTS</b> or <b>MPTS</b> for IPTV streaming. Setting to MPTS will change A and B IP port to one address, using the most recent setting.
CVCT	Activates inclusion of virtual channel ID and short Name in the video stream. <b>On (default)   Off</b>
Telnet Port	<b>23 (default)</b> IP port for Telnet communication – Click or hold Up or Down to set.
Setup Lockout	On or Off On locks out <b>Setup</b> button Pressing <b>Setup</b> and the <b>Right</b> key will unlock Setup until the QMOD is reset.
Save Data	Custom Reset – saves current settings to use for Reset
Reset	Select Factory Default or Custom settings
IP Speed	<b>Auto   100 Mbps</b>
Reboot	Left or Right arrow cycles between Reboots, AV Dropped, FIFO Full counts, reset counters from Web page

## Web Pages

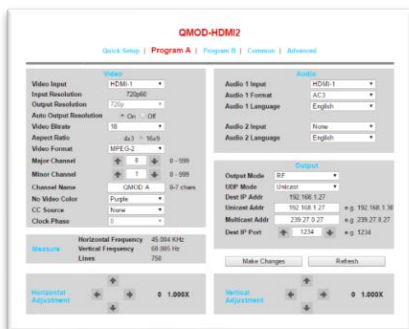

You can also access all the settings via the onboard Web pages. Access by pointing your browser to the unit's IP address. Or use the front-panel USB port this way:

- Go to Control Panel /Network and Sharing Center/Change Adapter Settings
- Right-click on the **USB Ethernet/RNDIS Gadget**, and right-click **Properties**
- Select **Internet Protocol Version 4**, select **Properties** and enter
  - IP Address: 192.168.227.1
  - Subnet mask: 255.255.255.0
- Enter 192.168.227.227 in your browser to see the QMOD web pages
- Once this is set, the same settings apply to all QMODs

# Updating Firmware with CR Toolbox

CR Toolbox is a PC application for many Contemporary Research products. When launched, CR Toolbox will search the network to discover connected devices, and list them in product-specific tabs. In addition, CR Toolbox will connect to the Contemporary Research SFTP server and check for updates. If CR Toolbox or firmware updates are available, notifications will appear in the appropriate sections.

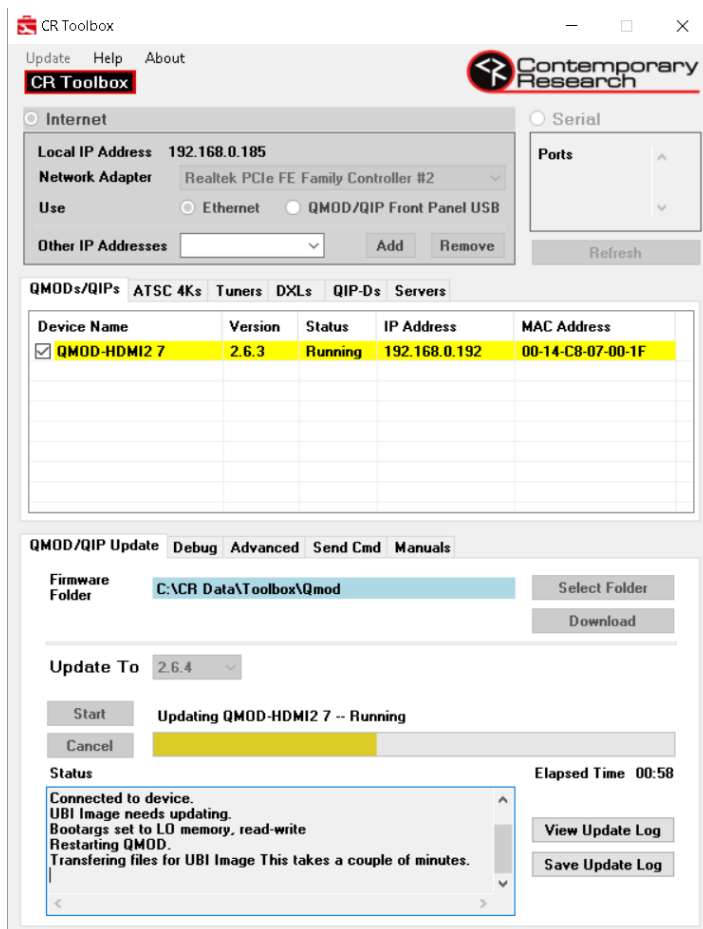

## Starting Up

Before traveling to a jobsite, download CR Toolbox from the [CR website](#). Select **Products**, then **Software**, select **CR Toolbox**, then select **Downloads** to download the software. Run after installing. CR Toolbox will then search the network for devices and populate the device list. In the **QMOD/QIP Update** section, click **Download** to add the latest firmware version to the CR Toolbox firmware library.

## Connecting to the QMOD or QIP Encoder

There are two connection options, Ethernet or USB. USB requires a USB Mini cable. For a direct Ethernet connection, a crossover cable is not required.

In Windows, access **Network and Internet/Change Adapter Settings**. Select **Properties** in the Ethernet Adapter, then **IP Version 4 Properties** and enter a compatible IP address.

Run CR Toolbox. The PC address will be confirmed at the top, and the encoder should appear in the QMODs/QIPs tab. At this point, you can click the name of the device to view the unit's Web pages.

To use USB, select the **QMOD/QIP Front Panel USB** and click **Refresh** to discover the encoder over USB.

To begin the firmware update, click the encoder's checkbox. If there are multiple encoders found on the network, select all the units and CR Toolbox will update each in sequence.

Select the latest version in the **Update To's** pull-down menu. Select **Start** to begin the update process. The process takes a number of steps, updating several software modules, and can take several minutes to complete. At times, part of the process may fail, but operation is not affected. Restarting the installation often succeeds. If there is a persistent issue, call CR Support at 888-972-2378. Keep CR Toolkit open, as you may need to select **View Update Log** to analyze the problem. You can also Save the update log if you plan to contact support at a later time.

## Converged RF and IPTV Distribution

---

QMODs can distribute MPEG2 and/or H.264 (MPEG4 AVC) over RF and IP.

For Program A and Program B, you can independently assign MPEG2 or H.264 encoding, as well as distribution over RF only, IP only and RF plus IP. Here's how this works for typical applications:

- **Dual-Program RF or IP only Distribution**
  - Dual RF only would typically use MPEG2 encoding, and will create a single MPTS (Multiple Program Transport Stream) stream with two programs, usually identified as XXX.1 and XXX.2.
  - Dual IPTV will typically use H.264, distributing two independent SPTS (Single Program Transport Stream) IPTV streams, multicast or unicast. You can also choose AAC audio when you're only sending programs over IP (Programs over RF must be AC-3 or MP12).
- **Dual-Program IP and RF Distribution.** The QMOD encoder can create the most efficient streams for RF+IP distribution. In most cases, both programs would be encoded as MPEG2, as most TVs can't decode H.264 over RF.
  - The Dual RF+IP setting will create a single MPEG2 MPTS stream for RF, with two programs, usually identified as XXX.1 and XXX.2.
  - The Dual RF+IP setting will create two independent MPEG2 SPTS streams, multicast or unicast.
- **One-Program Split RF and IP Distribution.** This combination uses one encoder for MPEG2 for RF, and the second encoder for H.264 for IPTV. Both could be encoding video from the same source, or two different sources can be used.
  - Program A would be set for RF, encoding a single MPEG 2 stream, formatted as a QAM channel for RF.
  - Program B would be set for IPTV, encoding a single H.264 stream at a much lower bitrate for IPTV distribution.

Any other combination can be employed, and will follow the same structure:

- If two Programs assigned for RF, the encoder will format both into a single MPST stream.
- IPTV streams will always be independent SPST streams

### Unicast

This form of Video over Ethernet creates a link from the QMOD to a specific IP receiver. The pros are that this stream will operate over most current networks and routers. The takeback is that the stream can be viewed by one receiver at a time, and you need to set up the link within the QMOD.

### Multicast

Multicasting is a more intelligent solution, as you can broadcast the stream with a multicast address, and the routers switches do the work of sending and copying the stream to receivers that request it.

The usual catch for integration is that not all switches can handle multicasting. All of the site's routers and switches must have multicasting and IGMP enabled, which may require either software updates or new equipment. IGMP protocol restricts the routing of streams to only the receivers that request the media.

Multicast IP addresses range from 224.0.0.1 through 239.255.255.255, which are set aside for multicast streams. However, there are "reserved" combinations in that range that don't work efficiently, so you'll want to use addresses assigned by the IT department.

Typical "non-reserved" addresses include:

239.0.0.5	239.0.27.xxx (default CR IGMP group)
239.0.0.6	239.3.0.1
239.0.100.99	239.0.1.1

## Using VLC Media Player to Test Streaming

The simplest way to test IPTV operation is to use a PC with VLC Media Player onboard. For a streaming test, use your PC and QMOD off-line from a network. Use an IP cable between the PC and QMOD (it will auto-sense and make it a crossover cable). Set the QMOD's quad address to the same as your PC (usually 192.168.0.xxx or 192.168.1.xxx), set the last number on the QMOD to be different than your laptop. With this setup, you can test Unicast and Multicast streaming. If you stream over your network, Unicast usually works, but you'll shut down the network if it's not set up for Multicast. Get approval from your IT staff before doing a streaming test on an Ethernet network.

### QMOD Setup

Using the onboard Web Common page or front panel menus:

- Set the **Output Mode** to RF+Ethernet or Ethernet
- Select the **UDP Mode** to Unicast
- Enter the IP Quad address of your PC for the **Unicast Address**
- For **Multicast**, use the default multicast address
- The default **Destination IP Port** is **1234**, you can change if needed
- Click **Make Changes**

If your PC and the QMOD are on the same network, the video is now streaming to your PC. I'm using Unicast as most networks aren't set up for Multicast as yet. Unicast will easily work in your home or integrator shop. If you're at a customer's site, you'll want to get approval by the IT department before turning this feature on.

### VLC Setup



Launch VLC on your PC. If you need to download the software, make sure that you download the app from Videolan only – there are many phishing sites that include malware with the VLC download.

- Click the Media menu and select the Open Network Stream feature.
- Enter **udp://@:1234** or the port you defined above
- Click Play to watch the video
- Click the **Playback** menu and **Program** option to select Program A or Program B
- For multicast, include multicast group address as well, such as **udp://@239.0.27.34:1234**

## RKU Universal Rack Mount Kit

---

All Contemporary Research rack-mountable products will now include a Universal Rack Mounting Kit (RKU). The RKU will allow for mounting of a single unit or two units side-by-side in a 19" rack. One Universal Rack Mounting Kit will be included with the purchase of each product and will include the following parts:

- Two (2) Short Rack Ears
- One (1) Long Rack Ear
- One (1) Center Mount Tie-bar
- Six (6) 8-32 x 1/4" Screws
- Two (2) 4-40 x 3/16" Screws

### 2-Across Mounting

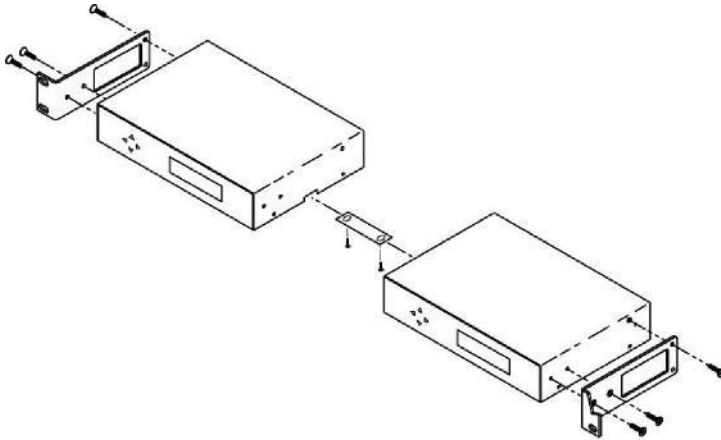

When mounting two components in one RU rack space, use the two short rack ears and the tie bar assembly. Note that the QDA4-45 and QCA9-33 have solid side panels and should not be mounted next to components with the ventilation holes, as that will block airflow.

- Check that your enclosures have the tie bar slot.
- Slide the included tie bar into the side of one unit and attach with one included 4-40 x 3/16" screw, but do not tighten.
- Slide the other unit into the tie bar, attach with the second 4-40 x 3/16" screw, and tighten both screws.
- Add the rack mounts to the sides using the six 8-32 x 1/4" screws.

### Single Unit Rack Mounting

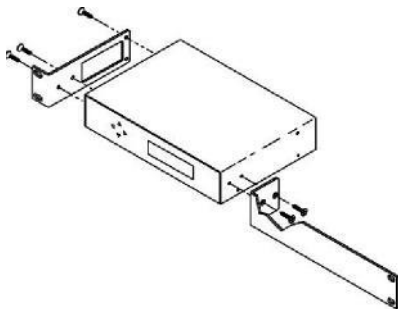

Attach a long and short rack ear to each side at the front of the unit, using five of the 8-32 x 1/4" screws.

## Specifications

---

<b>Physical</b>	8.5" [216mm] wide x 1.73" [62mm] height (1RU) x 6.0" [153mm] deep 1.5 lbs [0.68kg] +32° to 122° F operating temperature, convection cooled Rack mounting for one or two units side-by-side optional (RK1, RK2EZ)
<b>Front Panel</b>	Select and directional buttons for menu setup Menu LCD, Blue with 2 lines of 20 white characters each
<b>Scaling</b>	Dual hardware scalers Accepts 480i – 1080p video and various computer graphics resolutions, including 1080psf24/23.97 Edge to edge presentation with zoom, shrink and X/Y axis positioning Native or scales to fixed output resolution, 1080p scaled to 1080i
<b>Encoding</b>	MPEG2/H.264 Profile:MP@HL for HD, MP@ML for SD, 1080i, 720p, 480p, and 480i/576i output resolution MPEG2 Video Encoding bitrate 10-25 Mbps, HD, 5-6 Mbps 480i, variable bitrate if set for IP output only H.264 Video Encoding bitrate 5-10 Mbps, HD, 2-4 Mbps 480i, or variable bitrate if set for IP output only Converts PCM or MPEG1, Layer 2 audio to stereo AC-3, AAC or MP12, pass-through AC-3 SAP Dual-language capability, second audio track is MPEG1, layer 2 Dual encoders can stream can output a simultaneous MPEG2 or H.264 QAM MPTS stream and separate IP SPTS streams, or one encoder can process an MPEG2 stream for QAM, and the second can process an H.264 IP stream
<b>Modulation</b>	Switchable 64/256 QAM, J83 Annex B, Interleaving Modes (128,1) MER 38 dB typical
<b>Compliance</b>	FCC Class B, ROHS, meets California standards
<b>Power</b>	2.1mm coaxial jack (inside center conductor positive) 1.1A maximum, 11.5 to 13.5 VDC, 12 VDC typical Option to use PS12-8-4Y Power Supply to drive up to 4 QMODs
<b>Rear Panel</b>	
<b>EAS</b>	3 GPI Pins for latching control, SW, NO for closure, V+ 5-12 VDC, Ground
<b>Video Inputs</b>	1080p at 60/59.94Hz, 1080i/720p at 59.94/60Hz, or 576i, 480p/480i at 29.97Hz, and PAL 1080p scaled to 1080i, others output at fixed or native resolution Most VGA resolutions, Widescreen option for 480i Accepts HDMI/SDI embedded Stereo/Dolby Digital44/ 48KHz audio (AC-3 pass-through) Available inputs vary with model
<b>HDMI</b>	HDMI 1.4a female, does not accept HDCP protected content
<b>SDI</b>	BNC Female SD-SDI @ 270Mb/s, HD-SDI @ 1.485Gb/s, 3G SDI Level A @ 2.970Gb/s Coax cable auto-equalizer for SD up to 460m, HD up to 230m (RG6)
<b>RGBHV</b>	RGBHV DB15 (QMOD-HDMI 1.5, -HDMI RGB)
<b>Component</b>	3 RCA (QMOD-YPB2) or included in RGBHV HD15 connector (QMOD-HDMI RGB, -HDMI 1.5)
<b>Composite</b>	NTSC /PAL Video: RCA female (480i/576i), 29.97 Hz, supplies line 21 Captioning
<b>Audio Inputs</b>	<b>Digital SPDIF:</b> Coax, PCM 44.1/48K sample rate <b>Analog L and R:</b> 2 stereo 3.5mm jacks or RCA (QMOD-YPB2) <b>HDMI</b> Embedded, 48K sample rate <b>SDI</b> Embedded Pairs 1-8, 44.1/48K sample rate
<b>RF Out</b>	'F', female, 75 ohm impedance Agile, channels 2-135 (48-860 MHz), standard, HRC, or IRC spacing 6 MHz bandwidth fits any open channel without interference to adjacent channels 1 KHz resolution, +/- 30 ppm accuracy, +/- 35 ppm stability 29 dBmV typical output power, attenuated in 5 steps, approx 4 dB
<b>Includes</b>	RKU Universal Rack Kit PS12-2 Switching power supply, 2A 12 VDC, fits in typical AC power strips PS12-8Y 8A power supply with Y cable to drive 2-4 QMODs (free at time of order)
<b>Options</b>	RK1 Single Rack Kit, RK2EZ Dual Rack Kit

## QAM Channel Chart, Center Frequency

Channel	Frequency	Channel	Frequency	Channel	Frequency	Channel	Frequency
2	57	36	297	75	531	119	765
3	63	37	303	76	537	120	771
4	69	38	309	77	543	121	777
5	75	39	315	78	549	122	783
6	81	40	321	79	555	123	789
95	93	41	327	80	561	124	795
96	99	42	333	81	567	125	801
97	105	43	339	82	573	126	807
98	111	44	345	83	579	127	813
99	117	45	351	84	585	128	819
14	123	46	357	85	591	129	825
15	129	47	363	86	597	130	831
16	135	48	369	87	603	131	837
17	141	49	375	88	609	132	843
18	147	50	381	89	615	133	849
19	153	51	387	90	621	134	855
20	159	52	393	91	627	135	861
21	165	53	399	92	633		
22	171	54	405	93	639		
7	177	55	411	94	645		
8	183	56	417	100	651		
9	189	57	423	101	657		
10	195	58	429	102	663		
11	201	59	435	103	669		
12	207	60	441	104	675		
13	213	61	447	105	681		
23	219	62	453	106	687		
24	225	63	459	107	693		
25	231	64	465	108	699		
26	237	65	471	109	705		
27	243	66	477	110	711		
28	249	67	483	111	717		
29	255	68	489	112	723		
30	261	69	495	113	729		
31	267	70	501	114	735		
32	273	71	507	115	741		
33	279	72	513	116	747		
34	285	73	519	117	753		
35	291	74	525	118	759		

## Safety Instructions and Warranty

---

Read before operating equipment.

1. **Cleaning** - Unplug this product from the wall outlet before cleaning. Do not use liquid cleaners or aerosol cleaners. Use a damp cloth for cleaning.
2. **Power Sources** - Use supplied or equivalent UL/CSA approved low voltage DC plug-in transformer.
3. **Outdoor Antenna Grounding** - If you connect an outside antenna or cable system to the product, be sure the antenna or cable system is grounded so as to provide some protection against voltage surges and built-up static charges. Section 810 of the National Electrical Code, ANSI/NFPA No. 70, provides information with respect to proper grounding of the mast and supporting structure, grounding of the lead-in wire to an antenna discharge unit, size of grounding conductors, location of antenna discharge unit, connection to grounding electrodes, and requirements for the grounding electrode.
4. **Lightning** - Avoid installation or reconfiguration of wiring during lightning activity.
5. **Power Lines** - Do not locate an outside antenna system near overhead power lines or other electric light or power circuits or where it can fall into such power lines or circuits. When installing an outside antenna system, refrain from touching such power lines or circuits, as contact with them might be fatal.
6. **Overloading** - Do not overload wall outlets and extension cords as this can result in a risk of fire or electric shock.
7. **Object and Liquid Entry** - Never push objects of any kind into this product through openings as they may touch dangerous voltage points or short out parts, resulting in a fire or electric shock. Never spill liquid of any kind on the product.
8. **Servicing** - Do not attempt to service this product yourself as opening or removing covers may expose you to dangerous voltage or other hazards. Refer all servicing to qualified service personnel.
9. **Damage Requiring Service** - Unplug this product from the wall outlet and refer servicing to qualified service personnel under the following conditions:
  - When the power supply cord or plug is damaged.
  - If liquid spills or objects fall into the product.
  - If the product is exposed to rain or water.
  - If the product does not operate normally by following the operating instructions. Adjust only those controls that are covered by the operating instructions. An improper adjustment of other controls may result in damage and will often require extensive work by a qualified technician to restore the product to its normal operation.
  - If the video product is dropped or the cabinet is damaged.
  - When the video product exhibits a distinct change in performance, this indicates a need for service.



**Warranty:** Three (3) year limited warranty on all parts and labor for Contemporary Research manufactured products. Contemporary Research warrants its manufactured products against defects in materials and workmanship for a period of three years from the day of purchase by authorized dealer. If Contemporary Research receives notice of such defects during the warranty period; Contemporary Research, at its option, will repair or replace products that prove to be defective.

**Exclusions:** The above warranty shall not apply to defects resulting from improper or inadequate maintenance by the customer, customers applied software or interfacing, unauthorized modifications or misuse, mishandling, operation outside the normal environmental specifications for the product, use of the incorrect, modified or extended power supply, acts of God, weather, or improper site operation and maintenance. *Please note Contemporary Research SSV-DX Display Express PC product carries a six month limited warranty.*

**Product Service:** Contemporary Research will test, repair, or replace the product or products without charge if the unit is under warranty. If the product is out of warranty, Contemporary Research will test, and then repair the product or products. The parts and labor charge will be estimated by a technician and confirmed by the customer prior to repair. All components must be returned for testing as a complete unit. Contemporary Research will not accept responsibility for shipment after it has left the premises.

**Technical Support:** Contemporary Research technicians will determine and discuss with the customer the criteria for repair and/or replacement. Contemporary Research Technical Support can be contacted through one of the following resources: e-mail support at support@crwww.com or phone at: 972-931-2728

**Return Material Authorization (RMA) Number:** Before returning a product for repair or replacement, request an RMA from Contemporary Research's technical support. Provide tech support with a return phone number, e-mail address, shipping address, product serial numbers and original purchase order number. Describe the reason for repairs or returns as well as the date of purchase. See the General RMA Terms and Procedures section for more information. RMA's are valid for 30 days and will be issued to authorized Contemporary Research dealers only. End users must return products through authorized Contemporary Research dealers. Include the assigned RMA number in all correspondence with Contemporary Research. Write the assigned RMA number clearly on the shipping label of the box when returning the product. All products returned for credit are subject to a restocking charge without exception.

**Voided Warranty:** The warranty does not apply if the original serial number has been removed or if the product has been disassembled or damaged through misuse, accident, acts of God, weather, modifications, use of incorrect, modified or extended power supply, or unauthorized repair.

**Shipping and Handling:** Contemporary Research will not pay for inbound shipping transportation or insurance charges or accept any responsibility for laws and ordinances from inbound transit. Contemporary Research will pay for outbound shipping, transportation, and insurance charges for all items under warranty, but will not assume responsibility for loss and/or damage by the outbound freight carrier. If the return shipment appears damaged, retain the original boxes and packing material for inspection by the carrier. *Contact your carrier immediately.*

**Products not under Warranty:** Payment arrangements are required before outbound shipment for all out of warranty products.

**General RMA Terms and Procedures:** RMA's are valid for 30 days and will be issued only to authorized active Contemporary Research dealers only.

- End users must return products through authorized Contemporary Research dealers. End users may be eligible for a RMA at the discretion of CR Technical Support.
- Before a defective product can be authorized to send in for repair, it must first go through the troubleshooting process with a member of the Contemporary Research Technical Support team.
- Products authorized for repair must have a valid RMA (Return Material Authorization) number.
- Contemporary Research Technical Support will approve the issue of an RMA number.
- An RMA number is to be included in all correspondence with Contemporary Research.
- The RMA number must appear clearly on the shipping label when the product is returned.
- A packing slip must be included on the inside of the box with the RMA number listed and reason for RMA return.
- Products received at Contemporary Research that do not have a valid RMA number clearly marked on the outside of the shipping container may be refused and returned to sender.
- Boxes showing external damage will be refused and sent back to the sender regardless of the clearly marked RMA number and will remain the responsibility of the sender.

**Advanced Replacement Policies:**

For Contemporary Research manufactured products, advance replacement will be provided for "out-of-the-box" failures up to thirty (30) days after the initial shipment of products.

*Shipments of equipment that are refused upon attempted delivery, for any reason, are subject to restocking charges.*